

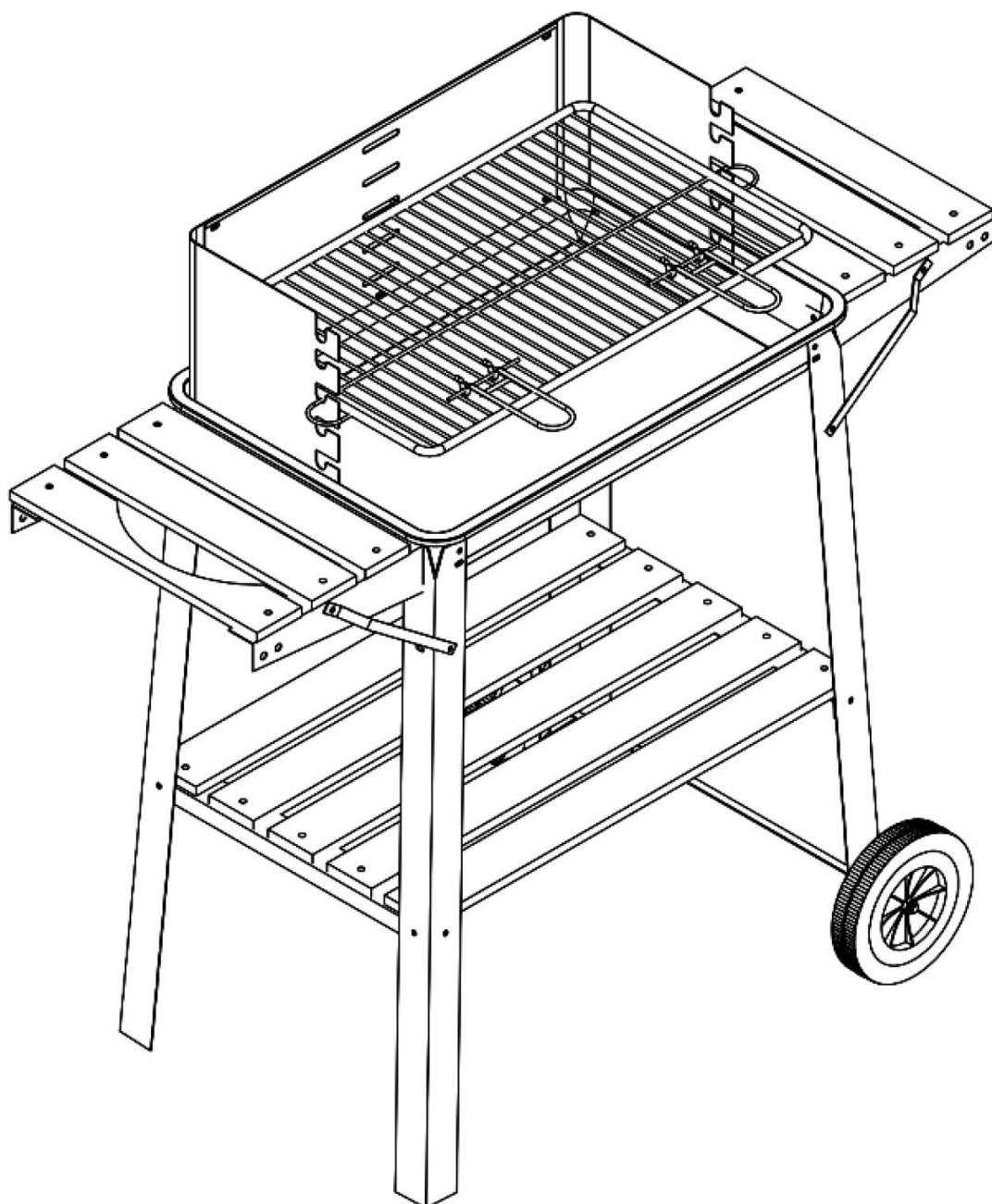

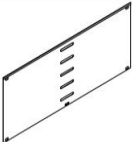

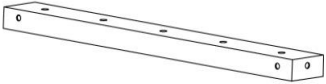

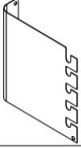



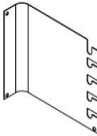
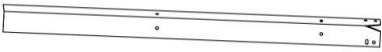
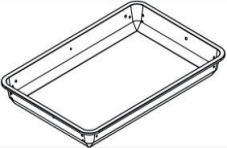
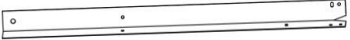



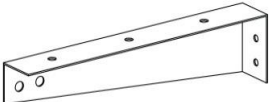

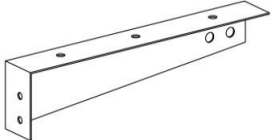
Návod k montáži – Zahradní gril na dřevěné uhlí HYD-ZG-D GDU06

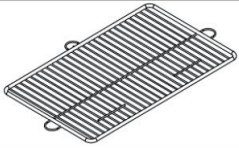

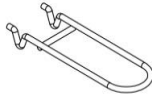
1		1	11		1
2		1	12		1
3		1	13		1
4		1	14		1
5		1	15		1
6		5	16		2
7		2	17		1
8		2	18		4
9		5	19		1
10		1	20		2

A	M5X12 	35	C	M6 	2
B	M5X20 	22			

Krok 1

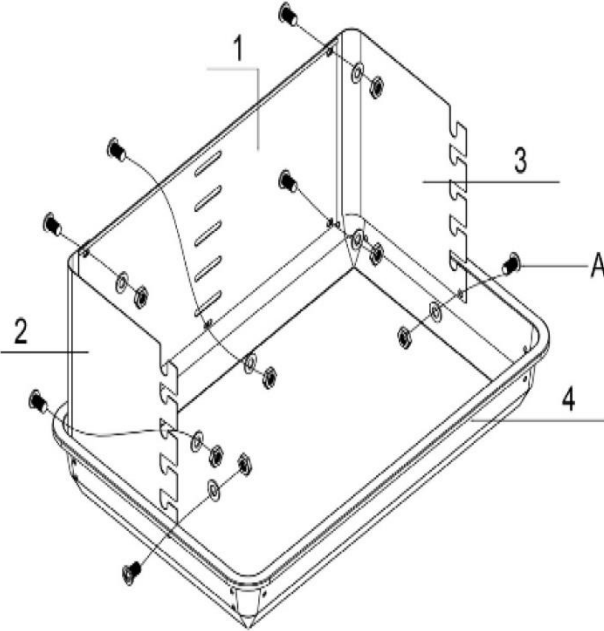

A:M5X12  7

Krok 2

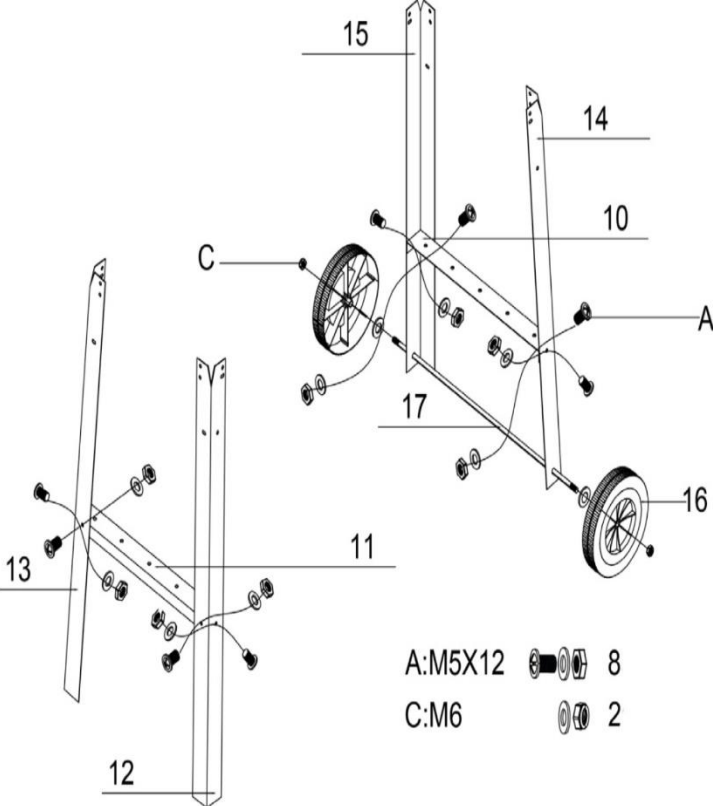

A:M5X12  8

C:M6  2

Krok 3

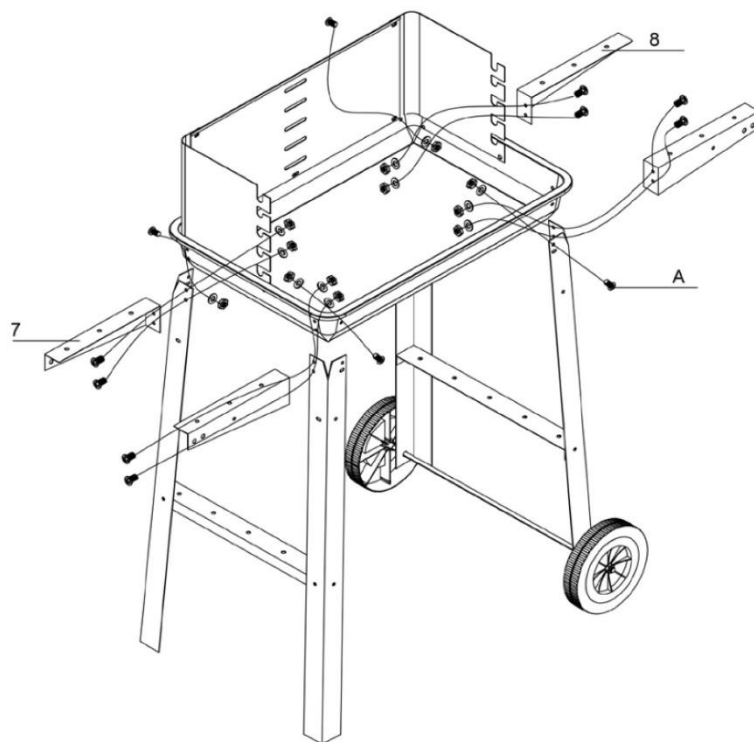

A:M5X12  12

Krok 4

B:M5X20  22

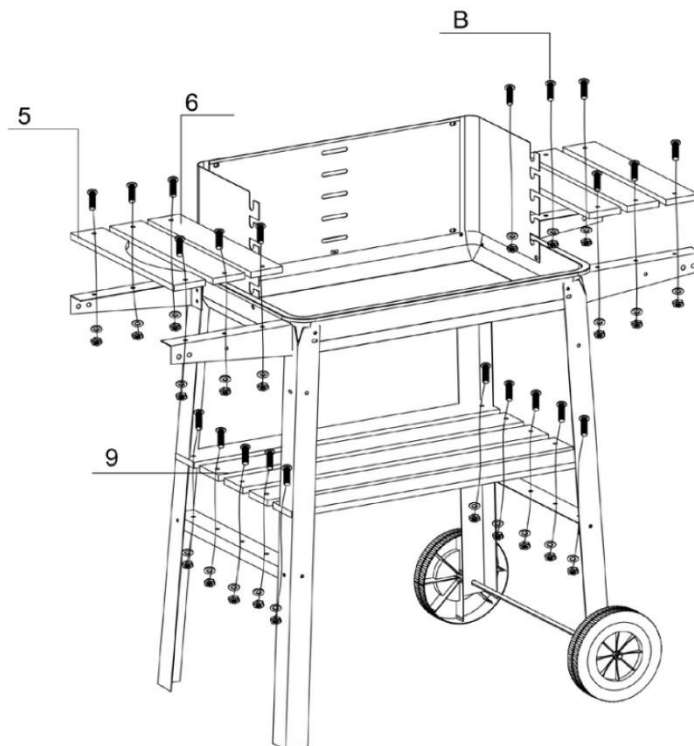

Krok 5

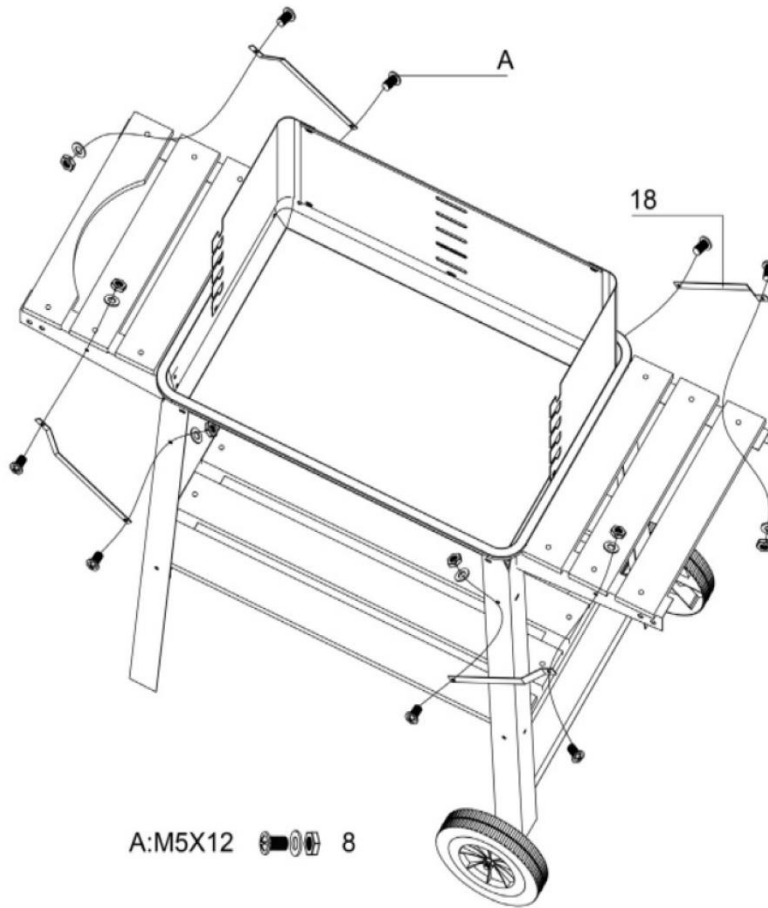

Krok 6

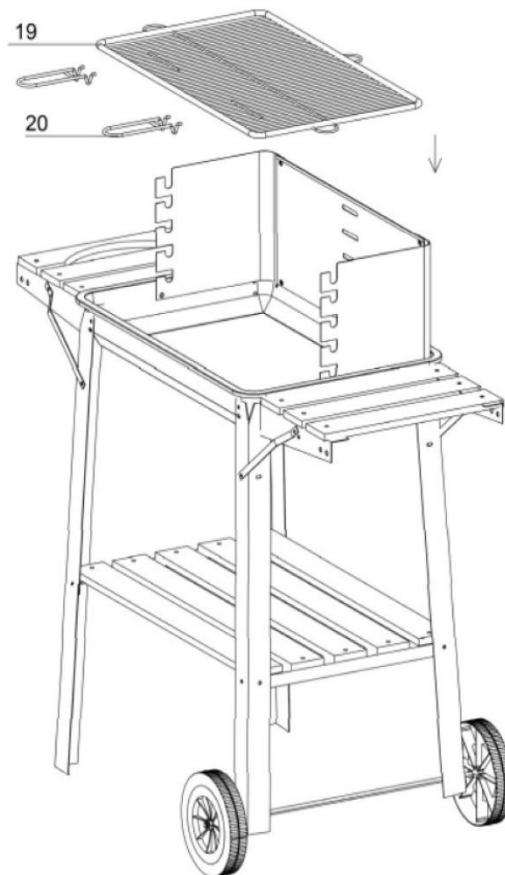

Poučení:

- K zapalování nepoužívejte líh ani benzín a po zhasnutí znovu nezapalujte!
- Uchovávejte mimo dosah dětí a domácích zvířat!
- Pevně a bezpečně sešroubovaný gril postavte na vodorovný, rovný a stabilní povrch.
- Neměňte polohu roštu, pokud jsou na něm potraviny.
- Horký rošt držte v ochranné rukavici, nikdy ne nechráněnou rukou.
- Po skončení grilování se popel uhasí vodou nebo se zakope do země.
- Pokud necháte popel v grilu, hrozí nebezpečí požáru!
- Při prvním použití je třeba gril řádně zahřát a udržovat palivo v žhavém stavu.
- Jako palivo používejte dřevěné uhlí nebo dřevěné brikety. Maximální množství paliva nesmí překročit kapacitu topeniště. Palivo nesmí přesahovat horní okraj topeniště.
- Zapalte oheň pomocí pevných podpalovačů. Na podpalovač položte několik uhelných briket a zapalte podpalovač. Jakmile oheň vzplane, přidejte palivo v požadovaném množství.
- Potraviny vkládejte na gril až po řádném rozehřátí dřevěného uhlí.

Gril může být velmi horký, během provozu s ním nehýbejte! Nepoužívejte v interiéru!

